

Description

1/8 - 1HP

**VS
mini**



The VS mini drive is a full-featured, high-performance, “microsize” design. This significant size reduction has been accomplished without sacrificing the essential programming features of our larger drives.

The VS mini offers power and versatility for a wide range of applications including material handling, packaging, mixing, pumping, HVAC, commercial wash machines, recreation equipment (tread mills), overhead doors and general industrial applications. Available in both standard protected chassis and optional Din rail designs.

The “microsize” design features application-specific intelligent power module (ASIPM) devices and circuitry, a 16-bit microprocessor, surface-mounted devices for reliability and strength, and second generation insulated-gate bipolar transistor (IGBT) technology.

The VS mini is available in 1/8 through 1 HP, 115 VAC single-phase, 50/60 Hz models. Output is 3-phase, 0 to 230 VAC.

Performance Features

- Ratings: 1/8 to 1 HP at 115 VAC
- Constant torque overload rating: 150% for 1 min. (200% peak)
- DC injection braking, ramp to stop
- Electronic reversing
- Adjustable accel/decel: 0.1 to 999 sec
- Controlled speed range: 40:1
- Drive efficiency: 95%
- Displacement power factor: 0.98
- Output frequency: 0.1 to 400 Hz
- Output voltage: 0 to 230 VAC
- Frequency resolution: 0.1 Hz with digital reference 0.06 /60 Hz with analog reference
- Frequency accuracy (-10° to 50°C): 0.01% with digital command 0.1% with analog command
- Volts / hertz ratio: infinitely adjustable pattern
- DC injection braking: adjustable amplitude, duration, and current limit
- Torque boost: full range, auto
- Power loss ride-thru: 1 sec. min
- Speed search
- Auto restart
- 3 Critical frequency rejection settings
- Slip Compensation

Design Features

- 16-bit microprocessor logic
- Digital keypad operator
- Programmable form C contact for customer use: 1A at 250 VAC or 30 VDC
- 24 VDC control logic
- Carrier frequency: 2.5-10 kHz
- 8 Multi-speed settings
- Remote speed reference: 0-10 VDC (20K ohms) or 4-20 mA (250 ohms)
- Signal follower: bias and gain
- Analog monitor output: 0-10 VDC proportional to output frequency or current
- Over 70 programmable functions
- Fully EMC compliant when optional RFI filter connected
- MTBF: exceeds 28 years
- Protected chassis

Standards

- UL listed
- cUL
- IEEE STD 444 (ANSI-C343)
- IEC: 146A

Protective Features

- Current limited stall prevention during accel, decel and run
- DC bus CHARGE indicator
- Isolated operator controls
- Short circuit protection
- Ground fault protection
- UL 508C programmable electronic motor overload

Service Conditions

- Ambient service temperature: -10°C to 50°C (14° to 122°F)
- Ambient storage temperature: -20° to 60°C (-4° to 140°F)
- Humidity: to 90% non-condensing
- Altitude: to 3300 ft; higher by derating
- Service factor: 1.0
- Input voltage: single phase 115V, ±10%
- Input frequency: 50/60 Hz, ± 5%
- Phase sequence insensitive

Options

- Dynamic braking resistor (external)
- Din Rail Kit
- Auxiliary potentiometer card
- Remote keypad
- RS232/482/485 Modbus RTU Serial Communications (Call Factory)



Standard Drives

VS mini Drives - 1/8-1HP, 115V, 1-phase input, protected chassis enclosure, 230V, 3-phase output.

Rated Input Voltage	Drive Model Number CIMR-XCBM	Old Model Number GPD205-	Rated Output Current (Amps)	Nominal HP ⁽¹⁾	Drive List Price \$
115V, 1-Phase	A0P10	10P1	0.8	1/8	
	A0P20	10P2	1.5	1/4	
	A0P40	10P7	3.0	1/2 & 3/4	
	A0P70	1001	5.0	1	

(1) Horsepower rating is based on standard NEMA B 4-pole motor design as represented in NEC table 430.150 Full-Load Current, Three-Phase Alternating Current Motors



Rated Input Voltage	Drive Model Number CIMR-XCBM	Rated Output Current (Amps)	Nominal HP ⁽¹⁾	Physical Dimensions (in.)			Mounting Dimensions (in.)		Weight (lbs) ⁽²⁾	Standard Enclosure	Heat Loss (watts)	
				H	W	D	H1	W1				
115V, 1-Phase	A0P10	0.8	1/8	5.04		3.74	4.64	2.20	1.3	Protected Chassis	13	
	A0P20	1.5	1/4		2.68	4.25					22	
	A0P40	3.0	1/2 & 3/4		4.25	5.12	4.64	3.78			2.9	39
	A0P70	5.0	1			6.10					3.1	61

(1) Horsepower rating is based on standard NEMA B 4-pole motor design as represented in NEC table 430.150 Full-Load Current, Three-Phase Alternating Current Motors

(2) This data represents the drive weight only, not shipping weight.

Fig. 1

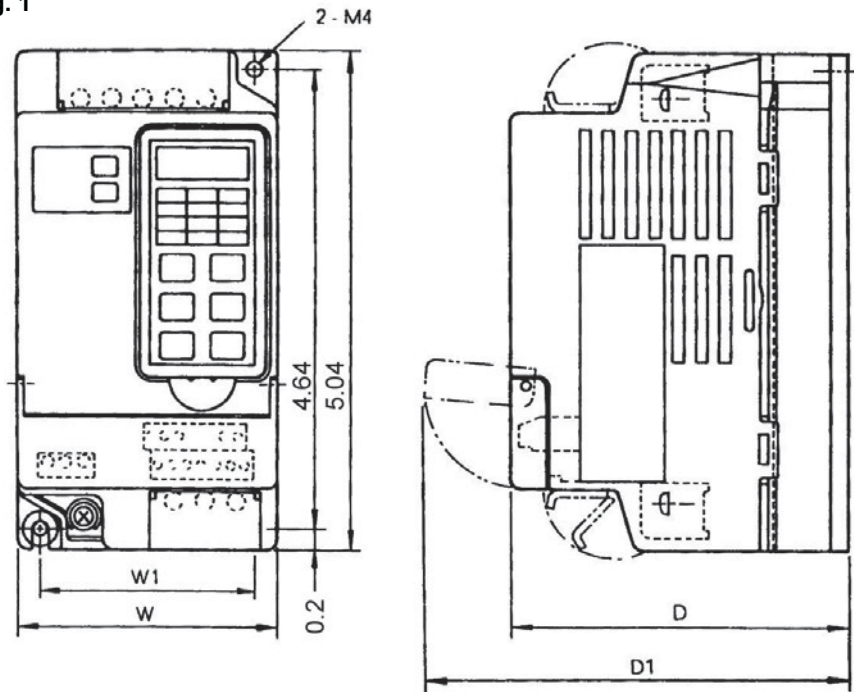
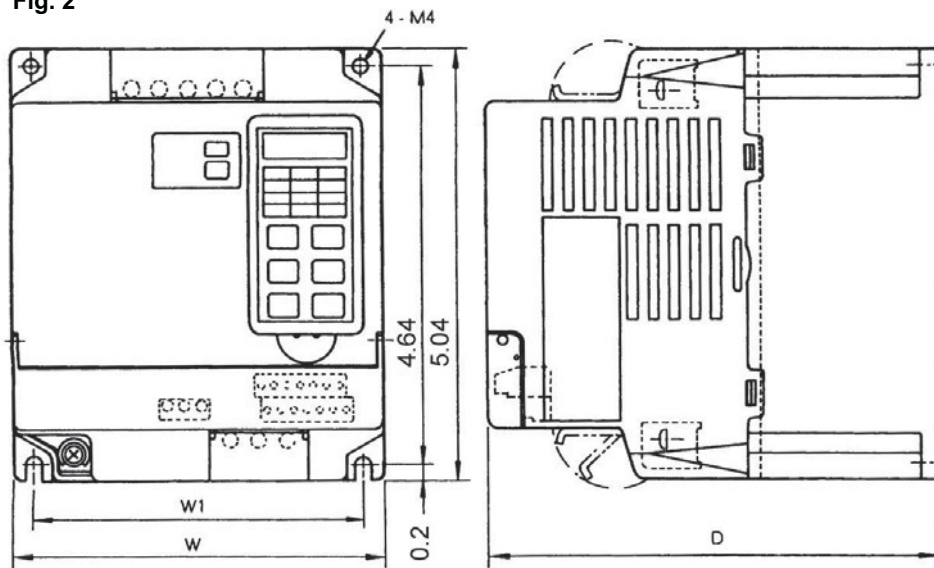

Fig. 2



Voltage	Model CIMR-XCBM	Output Current Rating (Amps)	HP	Dimensions in Inches						Figure	Approx. Weight (Lbs.)	Heat Loss (Watts)
				Mounting		H	W	D	D1			
				H1	W1							
115V, 1-Phase	A0P10	0.8	1/8	4.64	2.20	5.04	2.68	3.74	4.57	1	1.3	13
	A0P20	1.5	1/4	4.64	2.20	5.04	2.68	4.25	5.09		1.3	22
	A0P40	3.0	1/2 & 3/4	4.64	3.78	5.04	4.25	5.12	5.94	2	2.9	39
	A0P70	5.0	1	4.64	3.78	5.04	4.25	6.10	6.93		3.1	61